

A Prototype for NSDI Domain Data Server Node

*R K Goel, S. A. Shah, P. D. Yadav and Bharat Vaishnav
Informatics Applications Division, Space Applications Centre
Ahmedabad 380015, India*

ABSTRACT

Global Spatial Data Infrastructure (GSDI) is a platform for facilitating availability and sharing of spatial digital data to the users at global level. In the Indian context, efforts are being put for establishing National Spatial Data Infrastructure (NSDI) for facilitating the availability and sharing of up-to-date geo-spatial data along with associated attributes data and value added services to the users in India. This will certainly permit the spatial data users community to contribute in making cost-effective, in time and better decisions due to qualitative, assured and up-to-date data availability converging to the national economic growth, social progress and environmental well being.

The NSDI is visualised as a single window mechanism bridging spatial data users and the national and regional geo-spatial data domain agencies in the country. In order to make the spatial and associated attribute data available to user community, the active participation and commitment with NSDI is anticipated from various data domain agencies following proposed Metadata and data exchange standards. Thus, the data domain server will play a vital role in performing NSDI operations. To accelerate the development and sharing of best practices in NSDI implementation, increased participation is required on the legal, economic and technical working groups to create and collate common information resources and guidance for national and global reference and adoption.

This paper describes the approach for overall design and implementation of establishing a typical NSDI domain data server. It also discusses the role of data domain server for carrying out various functions and services to cater the requirements of the user community. In order to demonstrate the concept of NSDI domain data server, a prototype is developed in Intranet environment using the data available under NRIS Project. This prototype encompasses the following functions:

- Interfaces with the Metadata server like concurrent updation of metadatabase including the generation of thumb-nail data and reception/ processing of work-order from user via meta server.*
- Extraction of data requested from native database and conversion of extracted data as per proposed NSDE format.*
- Secured encryption of the NSDE formatted data product and utility for NSDE data viewer.*
- Utility for compression, decompression and decryption of NSDE data product.*
- Delivering mechanism for generated NSDE data product.*

This could serve as a guideline for establishing other NSDI-Data domain servers and its functions. This concept can be augmented further for implementing GIS based applications at State as well as National level.

1. Introduction and Background

Realisation of National Spatial Data Infrastructure (NSDI) is the current national focus in India. In this context, efforts are being put for evolving National Spatial Data Infrastructure (NSDI) for facilitating the availability and sharing of up-to-date geo-spatial data along with associated attributes data and value added services to the users in India.

The Indian NSDI is visualised as a single window mechanism bridging spatial data users and the national and regional geo-spatial data domain agencies in the country. As depicted in the figure below, NSDI in India is envisaged to be a network of domain specific data servers and a central metadata server working in unison to facilitate the data exchange amongst users and data supplying agencies.

NSDI Components

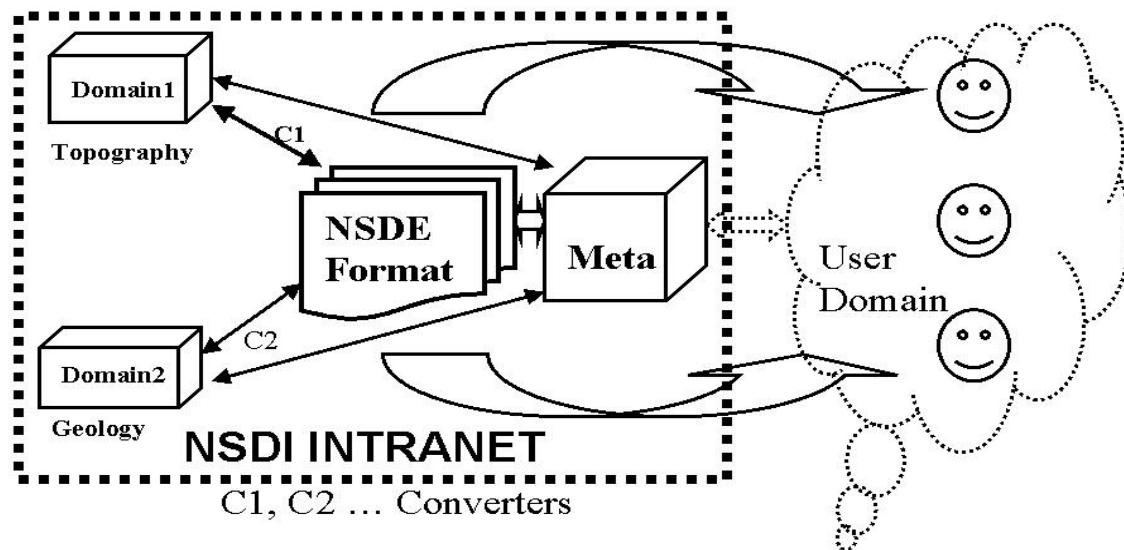

Considerable amount of work has been already carried out by various organisations in India, which has lead to definition of various NSDI components. These include:

- Evolution of Standard Exchange Format for Digital Vector Data (DVD) by Survey of India [11].
- Design and implementation of National Natural Resources Information System (NRIS) programme steered by Department of Space, Government of India [8,9]. NRIS is a network of GIS based nodes, created based on systematic database design principles. Each node covers resource information in the spatial domain. System encompasses information on natural resources related to land, water, forests, minerals, soils etc. and socio-economic information such as demographic data, amenities, infrastructure etc. Each node also has a set of decision support modules addressing various planning issues. The system is aimed at facilitating the

decision making process for systematic resources utilisation and aid sustainable development goals of the country. NRIS has clearly demonstrated the possibilities of creating digital databases for selected districts and proved its utility for the State/District administration in a decisive manner

- Setting up of a National task force by Department of Science and Technology, Government of India for defining various components of NSDI.
- Design of Metadata standards and demonstration of a prototype Meta server [1] by NSDI metadata working group commissioned by the NSDI task force.
- Design of National Spatial Data Exchange (NSDE) standards and concept proving exercises for affecting the exchange of data [2,3,15] by NSDI standards working group commissioned by the NSDI task force.

The domain data servers form the backbone of NSDI operations. This paper discusses the definition and design issues to be addressed prior to attempting the implementation of NSDI.domain data servers. Further, it anticipates the possible functions and services, which are likely to be carried out by a typical domain data server. Paper also attempts to enlist the processes and mechanisms to be established and various activities to be carried out for implementation of NSDI.domain servers. In order to demonstrate the concept of NSDI.domain data server functions and services, a prototype is developed in Intranet environment using the data available under National (Natural) Resources Information System (NRIS) programme of the Department of Space, Government of India.

2. Functions of a typical NSDI.Domain data Server

The prime responsibility of a typical domain data server is to serve the requisite data to a user based on demand received via NSDI Meta server. The data supply could be routed through the metadata server itself or it could be affected directly to the user employing various options like media transfer, FTP e.t.c. However, in order to facilitate the data supply to the user, the domain data server has to support various functions as listed in table below. The prerequisite for carrying out various services is that the creation and organisation of databases at each of the NSDI domains have to follow the NSDI design and standards framework. A large number of service functions have to be developed and implemented as per the computing environment vis-à-vis Operating System, the database management system and GIS package available at the target domain node. Quite a few of the service utilities can be developed and implemented independent of the domain server environment.

These could serve as a guideline for establishing NSDI.Domain data servers and development of software and hardware tools for realising the various functions and services of a typical domain data server.

Functions and services expected of typical NSDI.Domain database server	
Domain Data Server Function	Development Environment
Creation, maintenance and updating of the domain database.	<ul style="list-style-type: none"> - As per NSDI design template. - Computing environment specific to domain node
Validation/ vetting of server data elements	<ul style="list-style-type: none"> - As per NSDI standards template. - Computing environment specific to domain node
Interfaces with the metadata server like	Specific to domain node
<ul style="list-style-type: none"> - Concurrent updating of meta database - Generation of thumbnail data to be fed to meta server - Reception and processing of work-order from user via meta server 	
Extraction of data from domain database as per user request	Specific to domain node
Conversion of extracted data as per NSDE format	Specific to domain node
Secured encryption of the NSDE formatted data	Independent of domain environment
NSDE data Viewer	Independent of domain environment
Compression, decompression and decryption of NSDE data	Independent of domain environment
Delivering mechanism for generated NSDE data product	<ul style="list-style-type: none"> • NSDI Intranet • Media transfer
User accounting procedures.	Specific to domain node
Conversion NSDE format to global exchange standards following OGC, ISO-TC-211 standards and GML conventions	Independent of domain environment

3. Definition of NSDI.Domain Data Contents- The Pre Requisite

Domain data contents to hold the data will have to be defined for the heritage data and for the futuristic data that would form part of NSDI.Domain servers. This will include all the data that exists in analogue or digital form. The heritage data, to be committed to NSDI, may or may not have been created conforming to the published design standards available in the country. It is therefore necessary to keep a flag on such data sets, as these would require more elaborate efforts for making them conform to NSDI standards. To define the data contents the following tasks will have to be performed:

- Inventory of heritage data sets and identification of data to be committed to NSDI.Domain data servers along with the format (GIS or analogue)
 - Heritage data sets available in analogue format.
 - Heritage data sets available in GIS format but not organised as per any published design standards

- Heritage data sets available in GIS format and organised as per published design standards, if any
- List of futuristic data elements
- Identification of mutually exclusive layers and harmonisation of layer legends (specifically for similar layers coming from multiple agencies).

4. Formulation of Domain Policy Framework - Another Pre Requisite

To prevent ambiguity and for smooth functioning of NSDI.Domain servers, explicit policies are required, at each domain, for access privilege and security classification of data. Policy for data quality benchmark for each layer should also be laid down. Guidelines for realisation of regular mechanism for data quality evaluation and vetting are to be evolved. For each of the domain server nodes, Jurisdiction has to be identified in terms of data content and geographical location. The policies should be within the overall NSDI framework.

- Access privileges for each data content. Various options could be a) selected groups of persons within the repository agency, b) all users within repository agency, c) all Govt agencies in India, d) any agency or individual in India and e) global access
- Security Classification of each data element for example restricted/ open
- Data quality benchmarks for each layer (quality parameters/ declaratives as per NSDI task force guidelines)
- Guidelines for realisation of regular mechanism for data quality evaluation and vetting
- Geographic/ thematic jurisdiction of each domain server

5. Design of NSDI.Domain Servers

5.1 Design of Data bases

Further details regarding the actual design aspects will have to be worked out. The following tasks will have to be performed:

- Database server topology including placement of database servers by geographic criterion or by thematic criterion leading to identification of locations. This will be an important input to design of domain Intranet and specifying the networking requirements.
- Adoption of naming conventions for data layers and codification of layer content
- Finalisation of spatial framework including a) multiple layer registration scheme, b) projection/ co-ordinate system, c) spatial segmentation scheme for contents having nation-wide coverage and d) linkage schemes between spatial and aspatial components.

For carrying out the database design, the references can be drawn from **[3,8,9]**.

5.2 Identification of Networking Requirements

Each of the NSDI domains may be visualized as a network of nodes depending upon the geographical spread of the sub-units of repository agency. Internally, these servers could be addressing a closed user group within the agency Intranet. The users from other agencies can be provided access to NSDI.Domain servers via a gateway on the

NICNET or any other network decided upon by the national NSDI framework. However, the important point to be considered is that the system requirement specification from networking aspects will have to be worked out, in detail, for every domain. In this context, the following tasks will have to be performed:

- Server topology - Identification of Locations (input from database design exercise)
- Traffic load assessment
- Network backbone options
- Communication protocols between Web, Meta, domain data servers and clients
- Network management aspects
- Network access
- Network security
- Gateways to State, National and Global NSDI Network

5.3 Identification of S/W and H/W

NSDI.Domain servers have to be a constellation of GIS data servers. These data servers should be powerful enough to house, maintain and access all the heritage data and data that would be contributed to NSDI.Domain servers from time to time in future. Appropriate system requirement studies for S/W and H/W will have to be performed to address the following tasks:

- Consider System requirements and identify a) systems configuration, b) systems S/W, c) database creation and management S/W and d) networking S/W
- E-commerce/ user accounting S/W
- S/W required for establishing links to other networks like National NSDI, State SDI and GSDI.

6. Procedures and Tools for Data Management and Services

6.1 Re-organisation/ updation of heritage data sets

Each of the NSDI.Domain server nodes has to be populated with the data generated or likely to be generated by various agencies clubbed under the umbrella of a particular domain. It is certain that the data that has been generated in the past would not be available as per NSDI design standards. The data that will be contributed to NSDI.Domain servers will also have to be updated from time to time. Hence, procedures and tools for reorganisation/updation of heritage datasets will have to be designed and developed. In this context, following tasks will have to be addressed:

- Conversion of datum and projection systems, specifically for heritage data sets [7].
- Spatial segmentation of data layers.
- Feature code translations/ mapping as per NSDI.Domain server specifications.
- Incremental updation of domain databases.

6.2 Database Validation/ vetting Tools & Mechanisms

The quality of the database that has been contributed to NSDI.Domain servers will have to be validated and vetted. Tools and mechanisms to carry out the data validation and vetting will be required [8,9,12]. In this context, following tasks will have to be performed:

- Evolving mechanism for data quality evaluation.

- Development and implementation of automated procedures for structural verification of databases vis-à-vis laid down design.
- Interactive and /or manual procedures for verification/ correction of omissions and commissions.
- Automated/ semi-automated vetting of data prior to supply.

6.3 Data Search, Access & Service Tools

Appropriate S/W tools will have to be designed and developed for the following functions/ services:

- Thumbnail (JPEG format) generation, for populating the meta data.
- Concurrent updating of Meta server including thumbnail manager.
- Processing and interpretation of work order received from meta.
- Data Extraction as per user request routed through meta **[2,4,9,15]**.
- Exchange format conversion; Indian National format (NSDE version 1.0) **[2,4,9,15]**.
- Exchange data viewers; for facilitating quick examination of the data being received at user end **[6]**.
- Encryption/ decryption; for ensuring the security of data transfer over network **[5]**.
- Data compression; for affecting efficient data transfer rates over network.
- Procedures for transmitting the requisite data to client site; using network or using physical media.

7. Network and System management tools

Tools for network and system management will have to be designed. The following tasks will have to be addressed:

- Network management
- Network security
- Access Protocols
- Server system management

8. Organisational Structure

For smooth and efficient functioning of NSDI.Domain servers, management structure will have to be defined and teams/ committees will have to be identified to take up responsibilities in various functional and management areas. The teams will be required for executing the following tasks:

- Regular upkeep and maintenance of servers
- Management of domain databases including a) thematic Mapping, b) digital conversion and database updating and c) data quality evaluation and vetting
- Concurrent updating of meta database
- Database administration
- Systems maintenance
- Development and implementation of procedures for migrating to global standards and protocols like a) data exchange standards (e.g. ISO-TC-211, OGC), b) data search engines, c) data browsers/ viewers (e.g. GML).
- Apex body for regular review and clearances on a) design standards, b) migration to GSDI, c) addition of new data elements/ nodes.

9. Summary and Conclusions

The database design concepts and standards formulated as a part of NRIS project of Department of Space and the data exchange standards evolved by Survey of India in form of DVD have lead to formulation of National Spatial Data Exchange format (NSDE). This will provide a framework for data interoperability across various systems likely to be implemented at different NSDI Domain agencies. The database design approach followed under NRIS could be gainfully used for evolving the design of databases at various NSDI.Domain servers envisaged under National Spatial Data Infrastructure (NSDI). Our experience in the implementation of NRIS has shown that sound database design concepts followed-up with initial efforts on formulation/ design of standards and database creation/ management processes pay rich dividends in terms of ease of implementation and trouble shooting. The standards are neutral to platform and software packages hence they can be used in any configuration of hardware and software.

In this paper, we have discussed the definition and design issues to be addressed prior to attempting the implementation of NSDI.Domain data servers. Further, we have tried to anticipate and enlist the possible functions and services, which are likely to be carried out by a typical domain data server. We have also attempted to enlist the processes and mechanisms to be established and various activities to be carried out for implementation of NSDI.Domain servers. In order to demonstrate the concept of NSDI.Domain data server functions and services, a prototype is developed in Intranet environment using the data available under National (Natural) Resources Information System (NRIS) programme of the Department of Space, Government of India.

ACKNOWLEDGEMENTS

The authors thank Dr K N Shankara, Director, Space Applications Centre (SAC-ISRO), and Shri A R Dasgupta, Dy. Director, SITAA-SAC, for guidance, encouragement and support.

References

1. *NSDI Metadata Standard (with design of prototype NSDI Metadata), Sub-Committee on NSDI Metadata, ISRO-NNRMS-TR-104-2003, VERSION 3.0, A publication from National Natural Resources Management System, Indian Space Research Organisation, Bangalore, India.*
2. *National Spatial Data Infrastructure - Data Exchange Format (NSDI.NSDE version 1.01), in NSDI-2 Workshop at Ooty, India during, July 31- August 1, 2002. Released by NSDI in NSDI-3 workshop held at Agra India, during 12-14 November 2003.*
3. *Approach for Design of NSDI Domain Databases, R K Goel, in NSDI-2 workshop at Ooty India, during July 31- August 1, 2002.*
4. *Data Conversion from NNRMS-NRIS Data to NSDI-Spatial Data Exchange Format, Bharat Vaishnav, S. A. Shah, P. D. Yadav and R.K.Goel, in GSDI-7 at Bangalore India, during Feb 2-4, 2004.*

5. *Ensuring Data Security to NSDI-NSDE Data Product, P D Yadav, S. A. Shah, Bharat Vaishnav and R. K. Goel, in GSDI-7 at Bangalore India, during Feb 2-4, 2004.*
6. *NSDI-NSDE Data Viewer, S. A. Shah, P D Yadav, Bharat Vaishnav and R. K. Goel, in GSDI-7 at Bangalore India, during Feb 2-4, 2004.*
7. *Datum Conversion Procedure for Creating State Level Spatial Framework - A Case Study of NRIS Experience, P. M. Udani and R. Ghosh, in GSDI-7 at Bangalore India, during Feb 2-4, 2004.*
8. *National (Natural) Resources Information System (NRIS) - Design Concepts, A R Dasgupta and R K Goel, Proceedings, MapIndia-2002 organised by CSDMS, A-13, Sector 22, Noida, UP, India.*
9. *National (Natural) Resources Information System - NRIS Node design and Standards, A publication from National Natural Resources Management System, Indian Space Research Organisation, Bangalore, India.*
10. *National Geo-Spatial Data Infrastructure, by Lt. Col. (Dr.) R Siva Kumar, Member Secretary, NGDI Task Force. Article in ISG Newsletter, p20-23, March/June 2001.*
11. *Standard Exchange Format for Digital Vector Data released by Survey of India.*
12. *Ensuring the Integrity and validity of NRIS databases, Bharat Vaishnav, Ketki Kharod, P D Yadav & R K Goel, Proceedings, MapIndia-99, published by CSDMS, A-13, Sector 22, Noida, UP, India.*
13. *Design of Large Area Spatial Framework for NRIS, P M Udani, P D Yadav & R K Goel, Proceedings, MapIndia-99, published by CSDMS, A-13, Sector 22, Noida, UP, India.*
14. *National Spatial Data Exchange (NSDE) format under NSDI, S. A. Shah, P. D. Yadav and R K Goel, Proceedings, MapIndia-2002 organised by CSDMS, A-13, Sector 22, Noida, UP, India.*
15. *Data Exchange Between NRIS and Proposed NSDI- Spatial Data Exchange Format, Bharat Vaishnav, S. A. Shah and P. D. Yadav, Proceedings, MapIndia-2002 organised by CSDMS, A-13, Sector 22, Noida, UP, India.*



Mr. R K Goel specializes in realization of Geomatics based convergence solutions and has made significant contributions on:

- Conceptualization, design and realization of Spatial Decision Support Systems (SDSS).
- Evolving National Spatial Data Exchange mechanism as a member of NSDI standards working group.

Shri Goel has designed and organized multi-tier training programs on GIS for various educational/ training institutes and professional bodies.

His current interest is NSDI and E-governance. Currently, Mr. Goel is the Head of Informatics Applications Division at Space Applications Centre (ISRO), Ahmedabad.